

Catalog Number • Numéro de Catalogue • Número de Catálogo: HS-150

Country of Origin: Made in China • Pays d'origine: Fabriqué en Chine • País de origen: Hecho en China



SPECIFICATIONS

Voltage	120/277VAC, 50/60Hz
Power Consumption	Maximum 2.1 Watts
Load Rating	
@120 VAC	0-1800W tungsten or ballast, 15A receptacle; 1/2 hp
@277 VAC	0-1200W ballast
Egress Time Delay	30 seconds
Environment	Indoor use only
Operating Temperature	32° to 104°F (0° to 40°C)
Humidity	95% RH, non-condensing
Card Slot accepts standard size hotel card keys with dimensions	
.....	2.125"W x 3.375"H x 0.034"D
.....	(53.975mm x 85.725mm x 0.8636mm)
Tools Needed	
Insulated Screwdriver	
Wire Strippers	

DESCRIPTION AND OPERATION

The HS-150 is a line voltage card key switch that operates as a master switch to enable or disable power to single-pole electric branch circuits and loads in a hotel guest room or similar site. When a hotel door entry card key (or the key fob HS-FOB) is inserted in the HS-150 card slot, the controlled circuits are energized. When the hotel door entry card key (or HS-FOB) is removed, the controlled circuits will remain energized for 30 seconds more to allow safe egress from the hotel room. After this time delay elapses, they will be de-energized. To restore power to the room (that is, to the controlled circuits and loads), the occupant will need to reinsert the hotel door entry card key into the HS-150 card slot.

Lighted Card Slot

To help you locate the HS-150 in a dark room, two green LEDs illuminate the card slot where the hotel door entry card key or the key fob HS-FOB should be inserted. When the card or HS-FOB is in the slot, the green LEDs are **OFF**.

INSTALLATION AND WIRING

⚠ WARNING: TURN THE POWER OFF AT THE CIRCUIT BREAKER BEFORE WIRING. ⚠

1. Make sure that the power has been turned off at the circuit breaker.
2. Strip insulation off the wires to expose their copper cores to the length indicated by the "Strip Gauge" shown in Figure 1. Approximately 1/2".
3. Connect wires to the HS-150 flying leads as shown in the wiring diagram (Figure 2).
 - Connect the green or non-insulated (copper) GROUND wire from the circuit to the green terminal on the HS-150.
 - Connect the NEUTRAL wire from the circuit to the white wire on the HS-150.
 - Connect the power wire from the circuit box (HOT/LINE) to the black wire on the HS-150.
 - Connect the power wire to the loads to the red wire on the HS-150.
4. Put the HS-150 in the wall box and secure it to the wall box with the screws provided.
5. Attach the cover plate.
6. Restore power to the circuit.

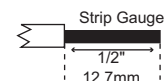
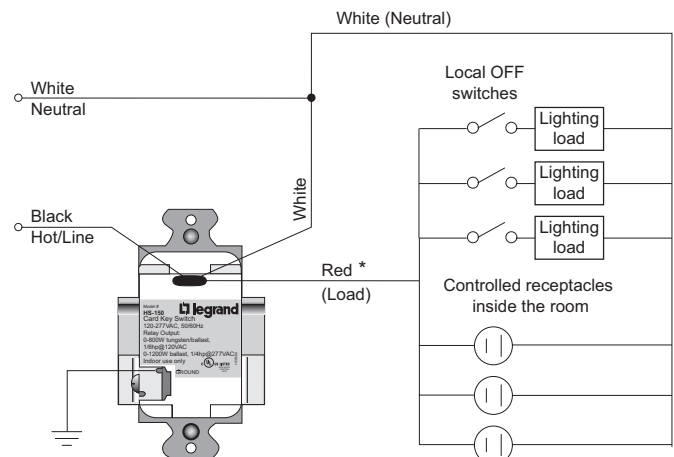

Figure 1: Strip Gauge



* **WARNING** - To prevent risk of damage to the unit - Do not exceed the HS-150's maximum 15 A load rating.

Figure 2: Line voltage wiring

TROUBLESHOOTING

Lighted card slot is OFF; no response from controlled loads in the guest room when card is inserted in slot.

- Make sure the circuit breaker that feeds the HS-150 and hence the controlled guest room loads is on and functioning.
- If the guest room loads are still not energized, turn power off and verify that the HS-150 is wired correctly and that all wire leads are tightly connected.
- If loads still do not respond properly after following troubleshooting, turn **OFF** power to the circuit and call Technical Support at 800.879.8585.

Lighted card slot is ON; no response from controlled loads in the guest room when card is inserted in slot or removed from it.

- Turn power off and verify that the HS-150 is wired correctly and that all wire leads are tightly connected. Turn power back **ON**.
- If there is still no response from the controlled loads in the guest room, call Technical Support.

When controlling multiple circuits in a room, call Technical Support at 800.879.8585 for diagrams.

ORDERING INFORMATION

Catalog Number	Description
HS-150-W	Line Voltage Card Key Switch; 120/277VAC, 50/60Hz
HS-100-W	Low Voltage Card Key Switch; 24VDC/VAC
HS-FOB-W*	Key Fob accessory for use when room access uses a standard key entry or other system without standard size hotel card key
HS-WP-W**	Cover plate for single-gang box
HS-WPR-W	Cover plate for triple-gang box with decorator switch option (card slot on the right)
HS-WPL-W	Cover plate for triple-gang box with decorator switch option (card slot on the left)

Hotel Card Key Switches, Key Fobs and Cover Plates are available in White

* Not needed when hotel uses card key entry system.

** One HS-WP-W included with each switch.

WARRANTY INFORMATION

Wattstopper warrants its products to be free of defects in materials and workmanship for a period of five (5) years. There are no obligations or liabilities on the part of Wattstopper for consequential damages arising out of, or in connection with, the use or performance of this product or other indirect damages with respect to loss of property, revenue or profit, or cost of removal, installation or reinstallation.

INFORMATIONS RELATIVES À LA GARANTIE

Wattstopper garantit que ses produits sont exempts de défauts de matériaux et de fabrication pour une période de cinq (5) ans. Wattstopper ne peut être tenu responsable de tout dommage consécutif causé par ou lié à l'utilisation ou à la performance de ce produit ou tout autre dommage indirect lié à la perte de propriété, de revenus, ou de profits, ou aux coûts d'enlèvement, d'installation ou de réinstallation.

INFORMACIÓN DE LA GARANTÍA

Wattstopper garantiza que sus productos están libres de defectos en materiales y mano de obra por un período de cinco (5) años. No existen obligaciones ni responsabilidades por parte de Wattstopper por daños consecuentes que se deriven o estén relacionados con el uso o el rendimiento de este producto u otros daños indirectos con respecto a la pérdida de propiedad, renta o ganancias, o al costo de extracción, instalación o reinstalación.