

VX4 Wireless Series User Guide

Wireless Energy Management Thermostat
with Built-in Occupancy Sensor and External
HVAC Controller



VERDANT
by COPELAND

Table of Contents

Introduction	6
SKUs Referenced in this Manual	7-12
Equipment Nomenclature.....	13
Installation Considerations.....	14
Network Installation (SKUs ending in 'XMF')	15
Notice.....	15
Connecting the Antenna Module.....	16
Connecting the Ethernet Cable.....	16
Powering the Server.....	16
Configuring the Online Connection Kit.....	17
HVAC Controller Installation	18
Introduction	18
Installing the HVAC Controller in 24VAC Relay Units.....	19
Using the Universal Input & Output Ports of the HVAC Controller	20
Using the HVAC Controller to Power a Wireless Thermostat.....	21
Using the HVAC Controller's Dry Contacts to Control External Devices.....	22
Thermostat Installation.....	23
Mounting the Thermostat.....	23
Sensor Installation (Optional)	24
Mounting a Remote Wireless Sensor	24
Voltage Adaptor Installation (Optional)	25
Motor less than 1/10HP.....	25
Motor greater than 1/10HP	26
Thermostat Configuration	27
Understanding the Thermostat Screen.....	27-29
Configuring the Thermostat	30
Pairing the Thermostat and HVAC Controller	31

Table of Contents

Setting the Mesh ID	32
Entering the Room Number.....	33
Configuring the Equipment Type.....	34
Configuring Energy Savings Settings	35
Setting the Thermostat Clock	36
Testing the Thermostat	37
Replacing Thermostat Batteries.....	38
Configuration & Managing Accessories.....	39
Activating a Sensor.....	39
Pairing a Sensor.....	40
Verifying Sensor Connection Status and Unlinking Sensors	41
Configuring the Functionality of a Sensor	42-43
Completing the Sensor Setup.....	44
Unit Specific Applications	45-51
Compatible Mitsubishi/Trane VRF Units.....	45
Installing the HVAC Controller.....	45
Configuring the Equipment Type	46
Compatible LG VRF & Inverter PTAC Units	47
Installing the HVAC Controller.....	47
Configuring the Equipment Type.....	48
Compatible GE HVAC Units.....	49
Installing the HVAC Controller.....	49
Configuring the Equipment Type	50
Configuring Occupancy Relay Output.....	51
Application Notes.....	52

Table of Contents

Custom Energy Savings Settings	53-103
Energy Settings Index.....	53
Using the Thermostat Settings Screens.....	54-66
01 - FAN CONTROL MODE.....	67
02 - 1 ST STAGE DIFFERENTIAL - HEAT.....	68
03 - 2 ND STAGE DIFFERENTIAL - HEAT.....	69
04 - 1ST STAGE DIFFERENTIAL - COOL.....	70
05 - INCIDENTAL OCCUPANCY THRESHOLD.....	71
06 - NIGHT OCCUPANCY THRESHOLD.....	72
07 - FORCED 2ND STAGE HEATING.....	73
08 - NIGHT OCCUPANCY START.....	74
09 - NIGHT OCCUPANCY END.....	75
10 - TEMPERATURE RECOVERY TIME.....	76
11 - RECOVERY TEMPERATURE - HEAT.....	77
12 - TEMPERATURE SETBACK DELAY.....	78
13 - MINIMUM SETBACK TEMPERATURE - HEAT.....	79
14 - MAXIMUM SETBACK TEMPERATURE.....	80
15 - RECOVERY TEMPERATURE - COOL.....	81
16 - MINIMUM SET POINT.....	82
17 - MAXIMUM SET POINT.....	83
18 - TEMPERATURE CONTROL MODE.....	84
19 - AUTO CHANGEOVER SET POINT OFFSET (DEAD BAND).....	85
20 - SETBACK SET POINTS.....	86
21 - AUTO-RESTORE.....	87
22 - N/A.....	88
23 - SETPOINT OVERSHOOT.....	89
24 - AUTOMATIC HUMIDITY CONTROL.....	90
25 - 2ND STAGE COOL DIFFERENTIAL.....	91
26 - SMART SETBACK.....	92
27 - HUMIDITY CONTROL THRESHOLD.....	93
28 - HUMIDITY CUTOFF TEMPERATURE.....	94
29 - N/A.....	95
30 - ENERGY MANAGEMENT ON/OFF.....	96
31 - DOOR/WINDOW SHUT OFF DELAY.....	97
32 - AUTO FAN SPEED 1ST STAGE DIFFERENTIAL.....	98
33 - AUTO FAN SPEED 2ND STAGE DIFFERENTIAL.....	99

Table of Contents

34 - TEMPERATURE CALIBRATION	100
35 - AUTOMODE TYPE.....	101
36 - HUMIDITY CONTROL IN OCCUPIED ROOM.....	102
37 - HEAT EQUIPMENT LOCKOUT.....	103
Troubleshooting	104
Restoring Factory Settings.....	104
Specific Applications.....	105
APPENDIX 1 - Energy Saving Presets	105-106
APPENDIX 2 - Equipment Codes	107-108
APPENDIX 3 - Glossary	109
Warranty Information.....	110
Technical Specifications	111-114

Introduction

Verdant VX Series Energy Management Thermostats deliver unprecedented energy savings without compromising the comfort of occupants.

An integrated occupancy sensor uses a combination of motion and thermal sensing technologies for accurate occupancy detection. Reliable occupancy detection allows for energy savings when rooms are unoccupied.

Energy saving presets eliminate the guesswork and make it easy to adjust the energy saving settings.

Fully configurable energy saving settings allow for customization of the thermostat settings to fit any situation.

Comprehensive configuration options ensure full compatibility with virtually any existing or emerging HVAC system with up to 4 heat and 2 cool stages.

Built-in wireless mesh-networking enables online management.

Introduction

SKUs Referenced in this Manual

This user guide includes instructions on how to install each of the following compatible SKUs.

Product Type	SKU(s)	Description
STANDALONE VX4 THERMOSTATS	VX4-TR-B	VX4 Wired Energy Management Thermostat PIR Occupancy Detection, Black
	VX4-TW-B	VX4 Wireless Energy Management Thermostat PIR Occupancy Detection, Black
	VX4-HW-B	VX4 Wireless Energy Management Thermostat PIR Occupancy Detection, Line Voltage, Black
	VX4-TW-B-GEA	VX4 Wireless Energy Management Thermostat PIR Occupancy Detection, Black, GE HVAC Plug & Play
	VX4-TVF-B	VX4 Wired Energy Management Thermostat PIR Occupancy Detection, Native VRF Integration, Black
	VX4-RSR-B	VX4 Wired Energy Management Thermostat PIR Occupancy Detection, VRF & Ductless Applications (Intesis/Airzone), Black
	VX4-TW-B-CV12	VX4 Wireless Energy Management Thermostat PIR Occupancy Detection, Black, Carrier VRF
	VX4-TW-B-MIE	VX4 Wireless Energy Management Thermostat PIR Occupancy Detection, Black, Mitsubishi & Trane VRF
	VX4-TW-B-LG	VX4 Wireless Energy Management Thermostat PIR Occupancy Detection, Black, LG VRF
	VX4-TW-B-TCAB	VX4 Wireless Energy Management Thermostat PIR Occupancy Detection, Black, Toshiba Carrier VRF
	VX4-TVF-B-CV12	VX4 Wired Energy Management Thermostat PIR Occupancy Detection, Native VRF Integration, Black, Carrier VRF
	VX4-TVF-B-MIE	VX4 Wired Energy Management Thermostat PIR Occupancy Detection, Native VRF Integration, Black, Mitsubishi & Trane VRF
	VX4-TVF-B-LG	VX4 Wired Energy Management Thermostat PIR Occupancy Detection, Native VRF Integration, Black, LG VRF
	VX4-TVF-B-TCAB	VX4 Wired Energy Management Thermostat PIR Occupancy Detection, Native VRF Integration, Black, Toshiba Carrier VRF

Introduction

SKUs Referenced in this Manual (cont'd)

Product Type	SKU(s)	Description
NETWORKED VX4 THERMOSTATS	VX4-TR-B-XMF	VX4 Wired Energy Management Thermostat PIR Occupancy Detection, Black, with Wireless Web Based Remote Management
	VX4-TW-B-XMF	VX4 Wireless Energy Management Thermostat PIR Occupancy Detection, Black, with Wireless Web Based Remote Management
	VX4-HW-B-XMF	VX4 Wireless Energy Management Thermostat PIR Occupancy Detection, Line Voltage, Black, with Wireless Web Based Remote Management
	VX4-TW-B-GEA-XMF	VX4 Wireless Energy Management Thermostat PIR Occupancy Detection, Black, GE HVAC Plug & Play, with Wireless Web Based Remote Management
	VX4-TVF-B-XMF	VX4 Wired Energy Management Thermostat PIR Occupancy Detection, Native VRF Integration, Black, with Wireless Web Based Remote Management
	VX4-TW-B-CV12-XMF	VX4 Wireless Energy Management Thermostat PIR Occupancy Detection, Black, Carrier VRF, with Wireless Web Based Remote Management
	VX4-TW-B-MIE-XMF	VX4 Wireless Energy Management Thermostat PIR Occupancy Detection, Black, Mitsubishi & Trane VRF, with Wireless Web Based Remote Management
	VX4-TW-B-LG-XMF	VX4 Wireless Energy Management Thermostat PIR Occupancy Detection, Black, LG VRF, with Wireless Web Based Remote Management
	VX4-TW-B-TCAB-XMF	VX4 Wireless Energy Management Thermostat PIR Occupancy Detection, Black, Toshiba Carrier VRF, with Wireless Web Based Remote Management
	VX4-TVF-B-CV12-XMF	VX4 Wired Energy Management Thermostat PIR Occupancy Detection, Native VRF Integration, Black, Carrier VRF, with Wireless Web Based Remote Management
VX4-TVF-B-MIE-XMF	VX4 Wired Energy Management Thermostat PIR Occupancy Detection, Native VRF Integration, Black, Mitsubishi & Trane VRF, with Wireless Web Based Remote Management	

Introduction

SKUs Referenced in this Manual (cont'd)

Product Type	SKU(s)	Description
NETWORKED VX4 THERMOSTATS	VX4-TVF-B-LG-XMF	VX4 Wired Energy Management Thermostat PIR Occupancy Detection, Native VRF Integration, Black, LG VRF, with Wireless Web Based Remote Management
	VX4-TVF-B-TCAB-XMF	VX4 Wired Energy Management Thermostat PIR Occupancy Detection, Native VRF Integration, Black, Toshiba Carrier VRF, with Wireless Web Based Remote Management
	VX4-RSR-B-XMF	VX4 Wired Energy Management Thermostat PIR Occupancy Detection, VRF & Ductless Applications (Intesis/Airzone), Black, with Wireless Web Based Remote Management
STANDALONE VX4 THERMOSTATS	VX4-NTR-B	VX4 Wired Smart 7-Day Programmable Thermostat, Black
	VX4-NTW-B	VX4 Wireless Smart 7-Day Programmable Thermostat, Black
	VX4-NHW-B	VX4 Wireless Smart 7-Day Programmable Thermostat, Line Voltage, Black
	VX4-NRSR-B	VX4 Wired Smart 7-Day Programmable Thermostat, VRF & Ductless Applications (Intesis/Airzone), Black
	VX4-NTW-B-GEA	VX4 Wireless Smart 7-Day Programmable Thermostat, Black, GE HVAC Plug & Play
	VX4-NTVF-B	VX4 Wired Smart 7-Day Programmable Thermostat, Native VRF Integration, Black
	VX4-NTW-B-CV12	VX4 Wireless Smart 7-Day Programmable Thermostat, Black, Carrier VRF
	VX4-NTVF-B-CV12	VX4 Wired Smart 7-Day Programmable Thermostat, Native VRF Integration, Black, Carrier VRF
	VX4-NTW-B-MIE	VX4 Wireless Smart 7-Day Programmable Thermostat, Black, Mitsubishi & Trane VRF
	VX4-NTVF-B-MIE	VX4 Wired Smart 7-Day Programmable Thermostat, Native VRF Integration, Black, Mitsubishi & Trane VRF
	VX4-NTW-B-LG	VX4 Wireless Smart 7-Day Programmable Thermostat, Black, LG VRF
	VX4-NTVF-B-LG	VX4 Wired Smart 7-Day Programmable Thermostat, Native VRF Integration, Black, LG VRF

Introduction

SKUs Referenced in this Manual (cont'd)

Product Type	SKU(s)	Description
	VX4-NTW-B-TCAB	VX4 Wireless Smart 7-Day Programmable Thermostat, Black, Toshiba Carrier VRF
	VX4-NTVF-B-TCAB	VX4 Wired Smart 7-Day Programmable Thermostat, Native VRF Integration, Black, Toshiba Carrier VRF
NETWORKED VX4 THERMOSTATS	Networked	
	VX4-NTVF-B-XMF	VX4 Wired Smart 7-Day Programmable Thermostat, Native VRF Integration, Black, with Wireless Web Based Remote Management
	VX4-NTW-B-XMF	VX4 Wireless Smart 7-Day Programmable Thermostat, Black, with Wireless Web Based Remote Management
	VX4-NHW-B-XMF	VX4 Wireless Smart 7-Day Programmable Thermostat, Line Voltage, Black, with Wireless Web Based Remote Management
	VX4-NTW-B-GEA-XMF	VX4 Wireless Smart 7-Day Programmable Thermostat, Black, GE HVAC Plug & Play, with Wireless Web Based Remote Management
	VX4-NTR-B-XMF	VX4 Wired Smart 7-Day Programmable Thermostat, Black, with Wireless Web Based Remote Management
	VX4-NRSR-B-XMF	VX4 Wired Smart 7-Day Programmable Thermostat, VRF & Ductless Applications (Intesis/Airzone), Black, with Wireless Web Based Remote Management
	VX4-NTW-B-CV12-XMF	VX4 Wireless Smart 7-Day Programmable Thermostat, Black, Carrier VRF, with Wireless Web Based Remote Management
	VX4-NTVF-B-CV12-XMF	VX4 Wired Smart 7-Day Programmable Thermostat, Native VRF Integration, Black, Carrier VRF, with Wireless Web Based Remote Management
	VX4-NTW-B-TCAB-XMF	VX4 Wireless Smart 7-Day Programmable Thermostat, Black, Toshiba Carrier VRF, with Wireless Web Based Remote Management
	VX4-NTW-B-MIE-XMF	VX4 Wireless Smart 7-Day Programmable Thermostat, Black, Mitsubishi & Trane VRF, with Wireless Web Based Remote Management
	VX4-NTVF-B-MIE-XMF	VX4 Wired Smart 7-Day Programmable Thermostat, Native VRF Integration, Black, Mitsubishi & Trane VRF, with Wireless Web Based Remote Management

Introduction

SKUs Referenced in this Manual (cont'd)

Product Type	SKU(s)	Description
	VX4-NTW-B-LG-XMF	VX4 Wireless Smart 7-Day Programmable Thermostat, Black, LG VRF, with Wireless Web Based Remote Management
	VX4-NTVF-B-LG-XMF	VX4 Wired Smart 7-Day Programmable Thermostat, Native VRF Integration, Black, LG VRF, with Wireless Web Based Remote Management
	VX4-NTVF-B-TCAB-XMF	VX4 Wired Smart 7-Day Programmable Thermostat, Native VRF Integration, Black, Toshiba Carrier VRF, with Wireless Web Based Remote Management

All Verdant VX Series thermostats are available in Black or White. For White thermostats, replace the letter "B" with the letter "W".

Network Equipment	ZX-OL-U	VX3, VX4 & ZX Online Connection Kit for Wireless Network Access*
Network Access	XMF	Wireless Network Access Fee
Integration Setup	ZX-OL-DLI-COM	Door Lock Integration - One Time Property Set-Up & Configuration
	ZX-OL-PMS-COM	PMS Integration - One Time Property Set-Up & Configuration
	ZX-OL-BAC-COM	BACNet Integration - One Time Property Set-Up & Configuration
EI	EI-1	Verdant EI Service - One (1) Year Subscription
	EI-2	Verdant EI Service - Two (2) Year Subscription
Lighting/Door Lock Integration	ACC-LIT-AOS-DC	Lighting Integration with Entryway Occupancy Sensor & RIBTE01B RIB Relay Included-12Vdc
	ACC-LIT-AOS-AC	Lighting Integration with Entryway Occupancy Sensor & RIB2401B RIB Relay Included-24Vac
	ACC-LIT-AC	Lighting Integration RIB2401B RIB Relay Included-24Vac
	ACC-LIT-DC	Lighting Integration RIBTE01B RIB Relay Included-12Vdc
	ACC-DK-1	Door Lock Integration - DormaKaba 1 Way
	ACC-ZIG-DK-2	Door Lock Integration - DormaKaba 2 Way
	ACC-AA	Door Lock Integration - Assa Abloy
	ACC-BLE-ONI	Door Lock Integration - Onity

Introduction

SKUs Referenced in this Manual (cont'd)

Product Type	SKU(s)	Description
Remote Sensors	ACC-AZA-D	Daikin Integration - Verdant Inverter/VRF
	ZX-AOS	VX3, VX4 & ZX Wireless Occupancy Sensor
	ZX-DWS	VX3, VX4 & ZX Wireless Exterior Door / Window Sensor With Magnet
	ZX-TWS	VX3, VX4 & ZX Wireless Temperature Sensor
	\$166-00004-01	VX3, VX4 & ZX Wireless Exterior Door / Window Sensor Magnet Pair
Wall Plates	ZX-WPT-ML	VX4 Thermostat Wall Plate
	ZX-CC-WPC	VX3, VX4 Controller Cover Plate
HVAC Controller	ZX-LV	VX3, VX4 & ZX HVAC Controller with Seven (7) Relays and Wire Harness (24V)
	ZX-HV	VX3, VX4 & ZX HVAC Controller with Seven (7) Relays and Wire Harness (120-277V)
	ZX-LV-SEC	VX3, VX4 & ZX Slave HVAC Controller with Seven (7) Relays and Wire Harness (24V)
	ZX-Y6-RR	VX3, VX4 & ZX Network Repeater
Wire Harnesses	0092 111800	Wire Harness & Screw Assembly Kit for VX4 Wireless Thermostat White
	\$830-00029-00	Wire Harness for VX3, VX4 & ZX Low Voltage Controller
	0092 111700	Wire Harness & Screw Assembly Kit for VX4 Wireless Thermostat Black
	0092 111400	Wire Harness & Screw Assembly Kit for VX4 Wired Thermostat White
	\$830-00027-00	Wire Harness & Screw Assembly Kit for LG Wireless Thermostat Controller
	\$830-00028-00	Wire Harness & Screw Assembly Kit for MIE Wireless Thermostat Controller
	0092 111500	Wire Harness & Screw Assembly Kit for CV12 Wireless Thermostat Controller
	0092 111600	Wire Harness & Screw Assembly Kit for TCAB Wireless Thermostat Controller
	0092 111300	Wire Harness & Screw Assembly Kit for VX4 Wired Thermostat Black

*Online Connection Kit is required to enable Wireless Web Based Remote Management. One (1) Online Connection Kit can accommodate up to 1,024 Networked Verdant Thermostats depending on property layout and configuration.

Introduction

Equipment Nomenclature

Before you begin installing Verdant equipment, we recommend you familiarize yourself with the various components that may be included in your shipment.



VX Thermostat & HVAC Controller



Online Connection Kit



Occupancy Sensor



Door/Window Sensor



Adaptor for VRF Systems

Introduction

Installation Considerations

Selecting the appropriate installation location of the thermostat and any accessories is crucial to the proper operation of your Verdant energy management system. The following guidelines should be adhered to in all cases;

THE THERMOSTAT'S OCCUPANCY SENSOR SHOULD FACE THE BED AREA OF THE ROOM OR THE AREA WHERE THE OCCUPANT WILL SPEND THE MOST TIME.

THE THERMOSTAT MUST NOT BE INSTALLED IN THE VICINITY OF LARGE METAL STRUCTURES OR SURFACES INCLUDING METAL AIR DUCTING THAT MAY BE IN THE WALL. LARGE METAL STRUCTURES BETWEEN THE THERMOSTAT AND CONTROL CARD AND/OR THE ONLINE CONNECTION KIT SUCH AS METAL CABINETS OR DOORS/ ELEVATOR SHAFTS SIGNIFICANTLY REDUCE THE RANGE OF THE WIRELESS SIGNAL AS THEY DEFLECT THE SIGNAL AND THEY DON'T ALLOW IT TO PASS THROUGH THEM, THUS REDUCING THE SIGNAL STRENGTH BETWEEN THE DEVICES MENTIONED.

DO NOT INSTALL THE THERMOSTAT NEAR WINDOWS OR DOOR VENTS, ON AN EXTERIOR WALL, ABOVE OR BELOW SUPPLY VENTS, OR OTHER LESS OCCUPIED AREAS.

Network Installation

NOTICE

TO ENABLE NETWORKING CAPABILITIES OF THE VX THERMOSTAT, REFER TO THE "NETWORK INSTALLATION" SECTION OF THIS MANUAL.

BEFORE STARTING THE INSTALLATION OF THE NETWORKED THERMOSTATS, ENSURE THE ONLINE CONNECTION KIT IS CONNECTED TO THE INTERNET.

CONFIRM THE ONLINE CONNECTION KIT IS COMMUNICATING PROPERLY WITH THE CLOUD SERVICE BY CALLING TECHNICAL SUPPORT AT 1 877 318 1823.

THE ANTENNA MODULE MUST BE INSTALLED WITHIN 100FT FROM THE FIRST 2 TO 3 THERMOSTATS, AND MUST NOT BE INSTALLED NEAR LARGE METAL STRUCTURES OR SURFACES.

TO PREVENT POWER RELATED ISSUES, PLUG THE SERVER INTO A UPS (UNINTERRUPTED POWER SUPPLY) UNIT.

Network Installation

Connecting Wireless Receiver

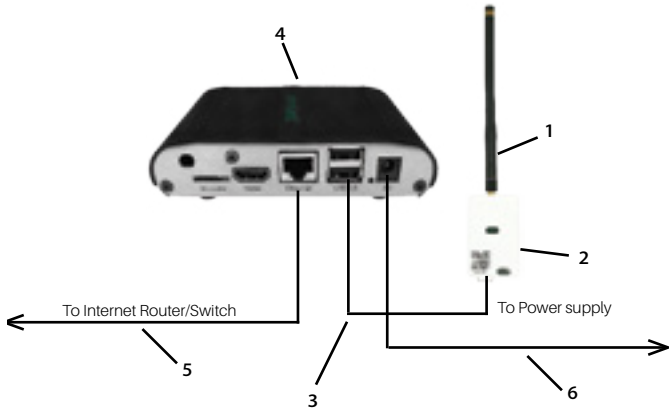

1. Screw Antenna (1) onto Wireless Receiver (2)
2. Connect Wireless Receiver (2) to Server (4) using supplied USB cable (3)
3. Affix Wireless Receiver (2) to wall with double sided adhesive tape
4. Orient Antenna (1) to point upwards to the closest room in which a thermostat will be installed
5. Connect Server (4) to the LAN port with the supplied RJ-45 cable (5)
6. Plug Server (4) into electrical outlet with power cord (6)

Network Installation

Configuring Online Connection Kit

1. Ensure Online Connection Kit is receiving an IP from a DHCP server.
NOTE: it is not recommended to use a public IP
2. Ensure MAC address is properly Whitelisted if it needs to bypass a login (splash) page to reach the internet
NOTE: MAC address is printed on a white sticker on bottom of Online Connection Kit.
3. If behind a firewall, OUTBOUND ports 22, 80, and 443 must be allowed for the Online Connection Kit. No INBOUND ports are required for this device unless specific options are requested.

HVAC Controller Installation

Introduction

Verdant HVAC Controllers enable wireless thermostat control of most HVAC units. The HVAC Controller has relay 24VAC outputs, analog 0-10VDC outputs, and digital data (RS485) outputs to allow for control of virtually any HVAC unit.

The illustration below indicates the various ports available on the HVAC Controller. Refer to the appropriate page in this manual for wiring instructions for your specific HVAC unit.

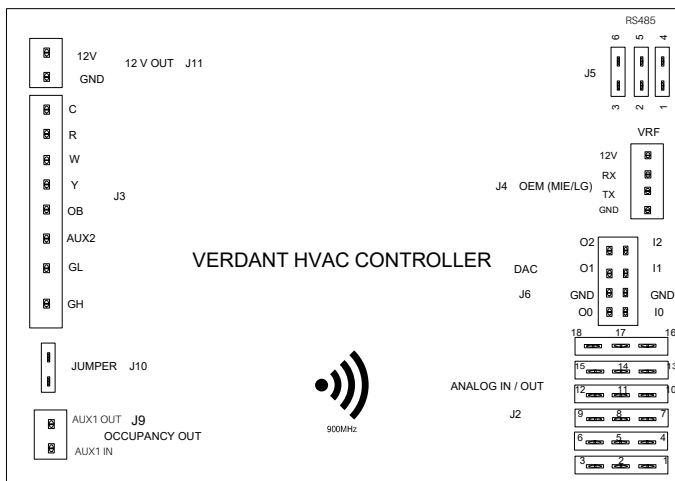

HVAC Controller Installation

Installing HVAC Controller in 24VAC Relay Units

1. Power Off HVAC unit
2. Mount HVAC Controller inside HVAC unit
3. Use supplied wire harness to connect HVAC Controller to HVAC unit
4. If applicable, set the unit to External Thermostat (Class 2) mode. Consult the HVAC unit documentation to determine how to set the unit to External Thermostat mode.

HVAC Controller 24VAC Relay Connections (J3 Port)								J9 Port
C Black	R Red	W White	Y Yellow	O/B Orange	Aux2 Brown	GL Purple	GH Green	AUX1 Blue
Common	24VAC	Heat	Cool	Reverse Valve	Aux2 Signal	Fan Low	Fan High	OCC
NOTE: Functionality may change due to equipment code, see Appendix 2 for further information.								

THE HVAC CONTROLLER ANTENNA MUST BE FACING THE THERMOSTAT AND MUST NOT BE TOUCHING OR ENCLOSED BY ANY METAL COMPONENTS IN THE HVAC UNIT.

THE HVAC CONTROLLER MUST BE MOUNTED SO IT CANNOT FALL INTO THE HVAC UNIT CONDENSATION PAN. USE PLASTIC CABLE TIES OR 3M COMMAND TAPE.

HVAC Controller Installation

Using Universal Input and Output Ports of HVAC Controller

The J6 port has three universal inputs, three universal outputs, and a ground. It functions in conjunction with the J2 jumper port and the J3 standard relay port. In cases where the standard 24 VAC relays of port J3 cannot control part of or all the analog controlled fan or heating/cooling modes of a specific HVAC system, the J6 port may be used to enable control of such a fan or mode (heating/cooling) or both fan and mode. A harness is provided for connections that require a J6 port.

The J6 port is often used in fan coil unit applications where the fan and heating and cooling valves are controlled using analog 0-10 or 0-3 VDC output signal on pins O0, O1, or O2. It may also be used as an input port, where I0, I1, or I3 can be set with a max of 12 VDC to read thermistors, take in 0-10VDC feedback, input wired occupancy, etc. Contact a sales representative if this setting is required.

The J2 jumper port is used in conjunction with J6, for selecting the device to be controlled per table below.

Output Connections (J6 Port)				
Output Number	O0	GND	O1	O2
Wire Color	White	Black	Yellow	Green
Set Functionality	Analog Heat	GND	Analog Cool	Analog Fan

Input Connections (J6 Port)				
Input Number	I0	GND	I1	I2
Wire Color	White/Black	Black	Yellow/Black	Green/Black
Possible Functionality	Aux Occupancy	GND	Thermistor	Feedback of 0-10VDC

Jumper Selection Pins (J2 Port)			
Connection Pins	Fan	Heat Mode	Cool Mode
1-2		X	
2-3			
4-5		X	
5-6			
7-8			X
8-9			
10-11			X
11-12			
13-14	X		
14-15			
16-17	X		
17-18			

HVAC Controller Installation

Using HVAC Controller to Power Wireless Thermostat (Optional)

The J11 port on the HVAC Controller may be used to supply 12VDC power to a wireless thermostat, if desired.

Use the supplied wire harness to connect the J11 port to the back of the wireless thermostat

12VDC Output (J11 Port)	
12VDC	GND

HVAC Controller Installation

Using HVAC Controller's Dry Contacts to Control External Devices

The J9 port on HVAC Controller can be used as a dry contact for control of external devices such as lighting relays and dampers. Refer to application notes for more information.

1. Connect jumper on J10 to create a wet contact supplying power from R&C.

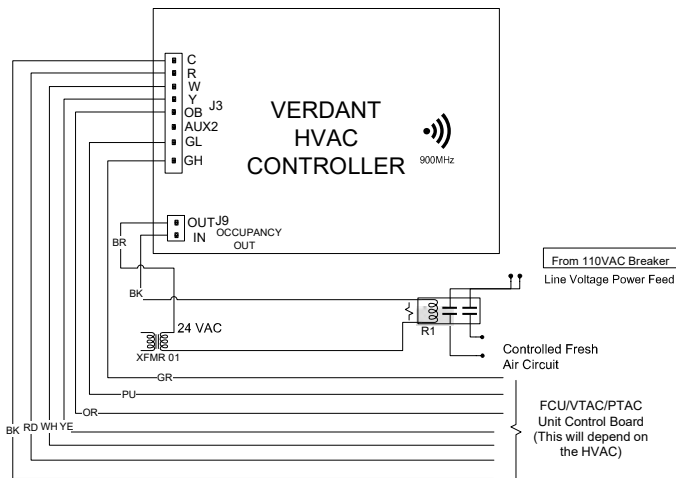

Thermostat Installation

Mounting Thermostat to Wall

1. Select appropriate installation location for thermostat per below:

THE THERMOSTAT'S OCCUPANCY SENSOR SHOULD FACE THE BED AREA OF THE ROOM OR AREA WHERE OCCUPANT WILL SPEND THE MOST TIME.

THE THERMOSTAT MUST NOT BE INSTALLED IN THE VICINITY OF LARGE METAL STRUCTURES OR SURFACES INCLUDING METAL AIR DUCTING. DO NOT INSTALL THERMOSTAT NEAR WINDOWS OR DOORS WHICH MAY ALLOW A DRAFT, ON AN EXTERIOR WALL, ABOVE OR BELOW SUPPLY VENTS, AND OTHER LESS OCCUPIED AREAS.

2. If using a wall plate, place it over hole in wall left from previous thermostat and mark two locations for drilling holes
3. Place thermostat on wall in installation location and mark location for drilling holes for two mounting screws

DO NOT OVER TIGHTEN THE BACK PLATE TO THE WALL. FOR UNEVEN SURFACES INSTALL A WALL PLATE.

4. Drill two 3/16" holes in wall and insert two wall anchors
5. Use two screws to securely mount thermostat to wall
6. Insert two AA alkaline batteries in thermostat. The thermostat can also be powered with 12vdc or 24vac

Optional Sensor Installation

1. Select appropriate installation location
2. With faceplate removed, place sensor on wall in installation location and mark location for drilling holes for two mounting screws

OCCUPANCY SENSORS SHOULD FACE THE DESIRED OCCUPANCY DETECTION AREA.

3. Drill two 3/16" holes in wall and insert two wall anchors
4. Use two screws to securely mount sensor to the wall
5. Insert one AAA alkaline battery into compartment (wireless sensors only)

Voltage Adaptor Installation

Installing Voltage Adaptor (Motor less than 1/10HP)

Fan Coil Adaptors (FCA) are used in applications where the Fan Coil Unit (FCU) in the controlled space has components, such as the fan motor or heating / cooling valves, that use a line voltage or a voltage exceeding 30VAC.

Where the Horsepower Rating of the Motor is less than 1/10 HP, the solution will include the FCA and the Metal Oxide Varistor used as control or compensation elements to provide optimal operating conditions and protect against excessive transient voltages.

Voltage Adaptor Installation

Installing Voltage Adaptor (Motor Greater than 1/10HP)

Where the Horsepower Rating of the Motor is greater than 1/10 HP, the solution will include the FCA and two relays.

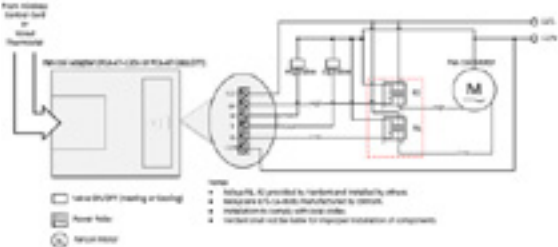

Thermostat Details

Thermostat Buttons

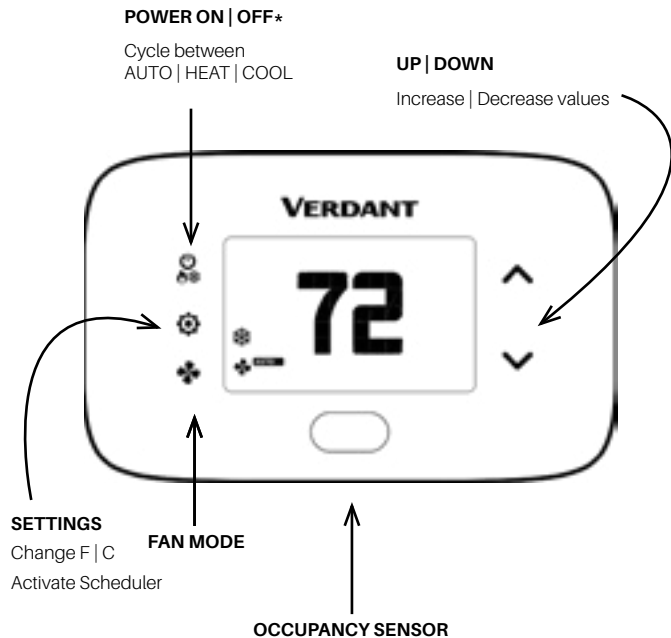

*In AUTO Mode, cycle between ON | OFF. In MANUAL mode, Cycle between OFF | HEAT | COOL

Thermostat Screen

Standard Display Screen (Typical)

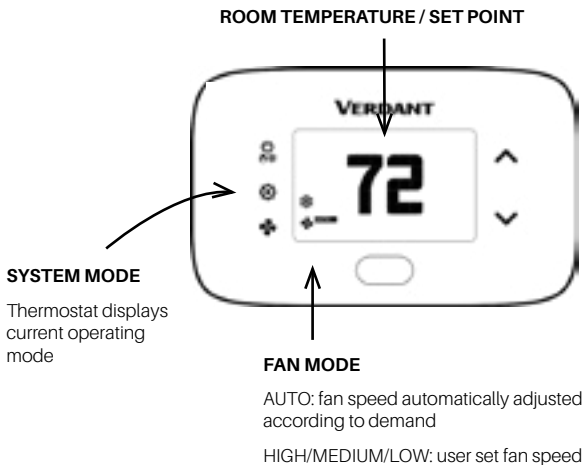

Thermostat Screen

Understanding Display Screen Icons

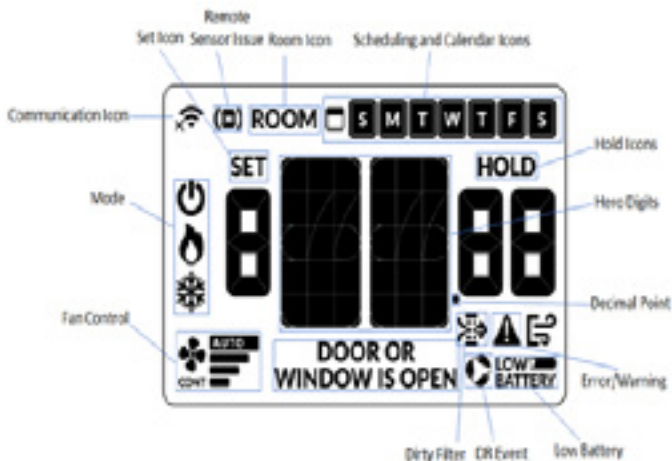

Thermostat Configuration

Configuring Thermostat



Prerequisites: During installation training with your support agent you will be provided with: Mesh ID (provided by Verdant Support), Room Number, Time, and Equipment Code. For VRF insert one jumper into function selection pins 2 and 3 of and another jumper in pins 5 and 6 at J5 on the control card.

To start with the configuration process, remove faceplate and insert 2 AA batteries.

Turn on thermostat and HVAC unit to activate setup screen (shown above) and complete the below settings shown the following pages:

1. Pair thermostat with HVAC Controller
2. Set MESH ID
3. Enter room number
4. Enter equipment code
5. Configure energy saving settings
6. Set thermostat clock
7. Enable/Disable Scheduler

Note: If the thermostat does not display SETUP when first powering the device, then it has already been paired to an HVAC Controller.

Thermostat Configuration

Pairing Thermostat with HVAC Controller

Each wireless thermostat must be paired with an individual HVAC Controller during installation. The thermostat will search for the closest HVAC Controller and display the unique HVAC Controller ID. The HVAC Controller ID is located on the case of the HVAC Controller. **Only install one room at a time.**



1. Press **SETTINGS** button. The thermostat will initiate a thirty (30) second countdown with a blinking connectivity icon before displaying the closest HVAC Controller ID
2. Verify HVAC controller ID found by thermostat matches the ID's last 5 digits listed on HVAC controller in the same room
3. Press **SETTINGS** button to pair thermostat with HVAC Controller displayed on the screen. The screen will display SUCC when the HVAC Controller has been paired successfully. If the HVAC Controller ID displayed on the screen is incorrect, press the FAN button to reject it and follow the bolded section below
4. If pairing is successful, wait 5-10 seconds and press **SETTINGS** button to advance to the Mesh ID configuration page.

- **If the HVAC controller ID displayed does not match, press the down button to see what other controllers are trying to connect with the thermostat. Keep pressing until you identify the matching controller number.**
- **If no controller ID is found, FAIL will appear on the screen. Press the ON | OFF button to get back to the initial setup screen and repeat procedure.**

Thermostat Configuration

Set MESH ID



For networked installations, a unique MESH ID is associated to each Online Connection Kit and is provided by your technical support agent during the installation training (also be found labeled on device).

For properties using a single Online Connection Kit, each thermostat may be linked to MESH ID 0001. For properties requiring multiple Online Connection Kits, each thermostat should be linked to the MESH ID of the closest Online Connection Kit.

1. Press **UP | DOWN** buttons to increase or decrease value
2. Press **FAN** button to advance to next digit
3. Press **SETTINGS** button to advance to next step

Thermostat Configuration

Entering Room Number



Enter room number by changing characters on screen. Available characters include digits 0-9 and letters A-F. To distinguish between two or more thermostats in the same unit, enter as follows:

Thermostat 1: 00100

Thermostat 2: 0100A

1. Press **UP | DOWN** buttons to increase or decrease the value
2. Press **FAN** button to advance to the next digit
3. Press **SETTINGS** button to advance to next menu

Entering room number correctly is crucial for proper operation of thermostats with online management.

Thermostat Configuration

Configuring Equipment Settings

Enter equipment code by changing digits on the screen.



1. Press **UP | DOWN** buttons to increase or decrease the value
2. Press **FAN** button to advance to next equipment setting
3. Press **SETTINGS** button to advance to next menu

NOTE: *default setting

Digit Value	Digit #1 Compressor Type	Digit #2 Electric Heat	Digit #3 Reversing Valve	Digit #4 Fan Speed
0	No Compressor	No Electric Heat	O/B Contact is energized to cool*	N/A
1	Heat Pump	Electric Heat*	O/B Contact is energized to heat	One Fan Speed*
2	Air Conditioner*	N/A	N/A	Two Fan Speeds
3	N/A			Three Fan Speeds

IMPORTANT: INSERTING INCORRECT EQUIPMENT CODE MAY CAUSE HVAC UNIT TO NOT OPERATE AS EXPECTED.

Thermostat Configuration

Configuring Energy Saving Settings



1. Press **UP | DOWN** buttons to increase or decrease energy savings preset
2. Press **SETTINGS** button to advance to next menu

*default setting

Preset	Energy Savings Presets
E-0*	Energy Savings Off - No Temperature Setback
E-1	Lowest Energy Savings
E-2	Lower Energy Savings
E-3	Standard Energy Savings
E-4	Higher Energy Savings
E-5	Highest Energy Savings

Thermostat Configuration

Set Thermostat Clock

Set thermostat clock to current time in 24h format.



1. Press **UP | DOWN** buttons to increase or decrease digits
2. Press **FAN** button to advance to next digit
3. Press **SETTINGS** button once to go to current room temperature screen

Setup is now complete

SETTING CORRECT TIME IS CRUCIAL FOR PROPER OPERATION OF THERMOSTAT. TIME UPDATES AUTOMATICALLY IF CONNECTED TO ONLINE CONNECTION KIT

Thermostat Configuration

Testing Thermostat

Following thermostat configuration, test if the thermostat is controlling the HVAC unit.

1. Ensure thermostat is powered and faceplate is affixed
2. Press **DOWN** button to change temperature set point below current room temperature to confirm thermostat initiates cooling
3. Press **UP** button to change temperature set point above current room temperature to confirm thermostat initiates heating
4. Change fan speed by touching **FAN** button to verify thermostat is controlling fan speed

Thermostat Maintenance

Replacing Thermostat Batteries

The low battery indicator is displayed on thermostat screen when necessary to replace batteries.

Under normal operating conditions, new brand-name alkaline batteries last for approximately 18 months. Replace batteries every 16 months to ensure continuous thermostat operation.

1. Remove thermostat cover
2. Replace two AA alkaline batteries
3. Re-affix thermostat cover
4. Press **ON | OFF** button to start thermostat.

NOTE: Thermostat maintains all previous configuration settings in non-volatile memory.

Configuring & Managing Accessories

Activating a Sensor

1. Remove faceplate from thermostat and from sensor(s) to be paired
2. Insert two AAA alkaline batteries into each sensor
3. Press button inside sensor to make sensor discoverable
4. Navigate to "Pairing a Sensor" on page <?>

NOTE: The sensor(s) will remain discoverable for five (5) minutes after pressing the button inside the device. If the pairing process has not been completed within five (5) minutes, push button inside sensor again.

Configuring & Managing Accessories

Pairing a Sensor

Ensure thermostat and HVAC unit are powered and thermostat faceplate is removed. The thermostat configuration screens have a 30-second time-out. If no action is taken within this time, the thermostat exits configuration settings.

1. Press and hold **CONFIG** button on thermostat to access Mesh ID screen
2. Press and hold **CONFIG** button again until **type** appears
3. Press **SETTINGS** button until **SENS** appears



4. Press **FAN** button on thermostat to initiate pairing of a new sensor ,or, press **SETTINGS** to manage existing sensors. This will initiate a 10 second countdown and display the last 5 digits of the sensor ID(s) discovered during the pairing procedure.
5. Use **UP | DOWN** buttons to toggle between discovered sensors
6. Ensure unique device ID displayed on screen matches unique device ID of sensor to configure
7. Press **SETTINGS** button when **Add** appears
8. Press **SETTINGS** button to pair selected sensor to HVAC Controller
9. Verify **SUcc** shows on screen

NOTE: If pairing fails, press **ON | OFF** button to exit and perform procedure again.

Configuring & Managing Accessories

Verifying Sensor Connection Status and Unlinking Sensors

NOTE: Thermostat and HVAC unit must be powered

1. Remove faceplate from thermostat
2. Press and hold **CONFIG** button until **MESH ID** appears on the screen
3. Press and hold **CONFIG** button again until **type** appears on screen
4. Press **SETTINGS** button again until **SENS** appears on the screen
5. Press **SETTINGS** button. The Thermostat will initiate a 10 second countdown before displaying the number of linked sensors currently communicating with the thermostat (e.g. 02.02 means 2 out of 2 linked sensors is communicating with thermostat)



6. Press **SETTINGS** button to display the first linked sensor and **UP | DOWN** buttons to cycle through linked sensors
7. After selecting sensor to be unlinked, press and hold **CONFIG** button. The thermostat will initiate a 10 second countdown before displaying the total number of linked sensors
8. Press **ON | OFF** button to exit this configuration menu
9. Press button on the sensor for 3 seconds until a yellow light turns on. The sensor is now reset and can be paired to the thermostat again if necessary.

Configuring & Managing Accessories

Configuring Functionality of Sensor

The thermostat allows the user to choose the functionality of a sensor. Use the table below to configure the desired functionality. For example, if sensor is intended to be used as Occupancy Sensor, OCC value must be set to 1.

NOTE: OCC default setting = 0



1. Press **SETTINGS** button to select sensor
2. Press **SETTINGS** button to move to Occupancy Sensor configuration screen **OCC** and use the **UP | DOWN** buttons to increase or decrease digit according to below table

Trailing Digit Value	OCC cx (Occupancy Sensor)	dsx (Door Switch)	rtx (Temperature Sensor)
0*	Disabled	Disabled	Disabled
1	Enabled	Normally Closed	Master
2		Normally Open	Average

Configuring & Managing Accessories



3. Press **SETTINGS** button to configure Door Switch functionality (dsx). Door switch functionality should be set to Normally Open (NO) or Normally Closed (NC) depending on reed switch
4. Press **SETTINGS** button to configure Temperature Sensor functionality (rtx)
5. Press **SETTINGS** button to move to **ADD** screen
6. Press **FAN** button to finalize pairing

Configuring & Managing Accessories

Completing Sensor Setup



The thermostat will countdown from thirty (30) seconds. If the sensor has successfully paired, the thermostat will display **SUCC**. If the sensor did not pair successfully, the display will read **FAIL**, and the procedure must be repeated.

1. Press **ON | OFF** button to exit sensor setup screen
2. Repeat Sensor setup as many times as necessary

Unit Specific Applications

Installing HVAC Controller for Mitsubishi Electric Trane HVAC US VRF Units

1. Power Off HVAC Unit
2. Mount HVAC Controller inside of HVAC unit
3. Connect one end of wire harness to J4 port on HVAC Controller
4. Insert one jumper into function selection pins 2 and 3 of and another jumper in pins 5 and 6 at J5 on the control card.
5. Connect other end of wire harness to METUS unit CN105 port

NOTE: If the space is unoccupied and humidity levels are high, the MIE Thermostat is able to manage the humidity levels using the Dry Mode of the indoor unit.



METUS Wire Harness

THE HVAC CONTROLLER ANTENNA MUST BE FACING THERMOSTAT AND MUST NOT BE TOUCHING OR ENCLOSED BY ANY METAL COMPONENTS IN THE HVAC UNIT.

Unit Specific Applications

Configuring Equipment Settings for Mitsubishi/Trane VRF Units



Enter equipment code 7703 by changing digits on screen.

1. Press **FAN** button to advance to the next equipment setting
2. Press **UP | DOWN** buttons to increase or decrease value to 7703
3. Press **SETTINGS** button to advance to next menu

Unit Specific Applications

Installing HVAC Controller for LG VRF Units

1. Power Off HVAC Unit
2. Mount HVAC Controller inside of HVAC unit
3. Connect one end of wire harness to J4 port on HVAC Controller
4. Insert one jumper into function selection pins 2 and 3 of J5. Insert another jumper in pins 5 and 6.
5. Connect other end of wire harness to LG unit CN-REMO port



LG Wire Harness

THE HVAC CONTROLLER ANTENNA MUST BE FACING THERMOSTAT AND MUST NOT BE TOUCHING OR ENCLOSED BY ANY METAL COMPONENTS IN THE HVAC UNIT.

Unit Specific Applications

Configuring Equipment Settings for LG VRF & Inverter PTAC Units



If LG Inverter PTACs are being controlled, enter equipment code 7713 by changing digits on screen. If LG VRFs are being controlled, enter equipment code 7723.

1. Press **FAN** button to advance to the next equipment setting
2. Press **UP | DOWN** buttons to increase or decrease value to 7703 | 7723
3. Press **SETTINGS** button to advance to next menu

Unit Specific Applications

Installing HVAC Controller for GE Units

This procedure is **only required** if the unit's Make Up Air will be driven by the thermostat.

1. Power Off HVAC Unit
2. Mount HVAC Controller inside of HVAC unit
3. Insert GE specific wire harnesses into corresponding J3 (controls) and J9 (occupancy) ports of HVAC controller
4. Insert other end of J3 harness into unit's External Thermostat Connector terminal and J9 harness into unit's CDC terminal
5. Insert jumper onto J10 port pins on controller



GE Wire Harnesses

Unit Specific Applications

Configuring Equipment Settings for GE V12 Units



Enter equipment code 1812 by changing digits on screen.

1. Press **FAN** button to advance to the next equipment setting
2. Press **UP | DOWN** buttons to increase or decrease value to 1812
3. Press **SETTINGS** button to advance to next menu

Unit Specific Applications

Configuring Occupancy Relay Output for GE Units

If unit's Make Up Air will be controlled by thermostat, occupancy output must be set to Normally Open (NO).

1. From room temperature screen, press and hold the **CONFIG** button to reach **n0001** screen
2. Press **SETTINGS** button to advance to room number screen
3. Press **SETTINGS** button to advance to equipment code screen
4. Press and hold **CONFIG** button to advance to **RST** screen
5. Press and hold **CONFIG** button to advance to **bt2.0u** screen
6. Press and hold **CONFIG** button to advance to **OCC** screen
7. Press **SETTINGS** button to advance to NC screen
8. Press **DOWN** button to advance to NO on screen
9. Press **ON / OFF** button to save changes

Equipment codes for GE V12 and other GE units:

Model	Equipment Code
V12 with or without Make Up Air	1812
PTAC with or without Make Up Air	2102
PTHP with or without Make Up Air	1112
VTAC A/C with or without Make Up Air	2102
VTAC HP with or without Make Up Air	1112

WHEN ROOM IS OCCUPIED THE MAKE UP AIR SHOULD WORK AS WELL. FOR THE FRESH AIR TO OPERATE ACCORDING TO GE'S SPECIFICATIONS, THE OCCUPANCY OUTPUT RELAY MUST BE SET AS NORMALLY OPEN (NO).

IMPORTANT: INSERTING THE WRONG EQUIPMENT CODE MAY CAUSE THE HVAC UNIT TO NOT OPERATE AS EXPECTED.

Application Notes

A comprehensive list of published application notes can be found at www.verdant.co/resources/application-notes.

Applications include (among others):

1. Energy Savings Settings
2. Scheduler
3. Door-lock ZigBee Integrated Solution
4. Demand Response
5. Hilton Connected Room
6. IHG Studio
7. Occupancy Based Lighting Control
8. Advanced Lighting Application: ZigBee Controlled Switch and socket from LEVITON

Custom Energy Savings Settings

If you do not want to use one of the energy saving presets detailed in Appendix 1, you can enter the custom energy savings settings.

Accessing Custom Energy Savings Settings

1. Ensure thermostat is powered and faceplate removed
2. Press and hold **CONFIG** button to access Mesh ID screen
3. Press **SETTINGS** button to navigate to Energy Saving Settings screen
4. From Energy Savings Settings screen, press and hold **CONFIG** button until first custom energy saving settings screen appears



Custom Energy Savings Settings

Using Thermostat Settings Screens

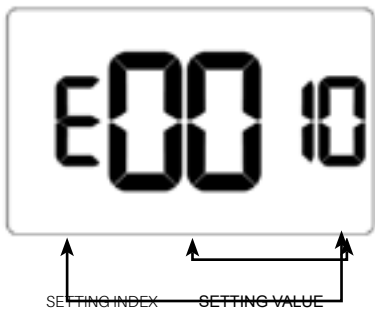

1. Use **UP | DOWN** buttons to select desired index setting
2. Press **CONFIG** button to edit value of index setting
3. Use the **UP | DOWN** buttons to change setting value (see Custom energy saving settings section for more info and Min-Max values)
4. Press **FAN** button to temporarily store setting value
5. Press **FAN** button to save profile and exit Custom Energy Savings Settings
6. To discard the changes, press **ON | OFF** button at any time

Custom Energy Savings Settings



Default value: enabled
Range: 7 days

Allows for setting of cooling and heating set points at varying times throughout the day.

The scheduler is enabled by default and let's the user set cooling and heating setpoints for different times for each day of the week.

The scheduler allows the thermostat to store up to 6 events for each day (7 days). Events #5 and #6 should be enabled via the web.

Custom Energy Savings Settings

Scheduler

Firmware version 1130 and higher is required for Scheduler feature.

1. Ensure thermostat is powered and operational
NOTE: Below illustration is an example. Temperature and fan mode can differ.



2. Press **SETTINGS** button until temperature value shows
3. Press **SETTINGS** again to activate scheduler and show current status (n or y)
4. Use the **UP | DOWN** button to select desired status



Custom Energy Savings Settings

5. Press **SETTINGS** button to navigate to first event of the week. Use Up / Down arrows to set event time.

NOTE: below example shows setting for second event.



6. Press **SETTINGS** button to display Set and press Fan button to select necessary day of the week. Press SETTINGS button when correct day is selected.

NOTE: go to Step 5 immediately after selecting correct day.



Custom Energy Savings Settings

7. Use **UP | DOWN** buttons to set cooling temperature to desired setpoint and press **SETTINGS** button.
8. Use **UP | DOWN** arrows to set heating setpoint.
NOTE: press **ON | OFF** button at anytime to exit scheduler menu.



9. Repeat Step 5 until all desired events are scheduled

Custom Energy Savings Settings

Door Lock Integration

Door Lock integration can be via 1-Way Communication or 2-Way Communication.

- 1-Way application: Door locks must be networked and communicating with a Door Lock Management System for thermostat integration
- 2-Way application: thermostat acts as the network. Door locks are not required to be networked. A ZigBee coordinator is also required for wired / wireless integration

NOTE: integration with dormakaba requires ebox and dorma server set-up and communicating.

NOTE: remove faceplate from thermostat before starting procedure

1. Press and hold **CONFIG** button until **MESH ID** appears
2. Press and hold **CONFIG** button until **type** appears
3. Press **FAN** button until **Select** shows on screen

NOTE:

Wireless: countdown appears to confirm pairing to control card

Wired: no countdown



Custom Energy Savings Settings

4. Press **DOWN** button to display **Add** and then press **SETTINGS** button to display select list.



5. Press **DOWN** button until desired lock platform shows (oni or kaba) and then press **SETTINGS** (below example only)



6. Allow countdown to complete until screen displays **Found[1-8]**.



Custom Energy Savings Settings

- Use **DOWN** button to scroll through found devices with **Eul_[lockid]_255** format.

NOTE

- Dorma locks display as lock's respective short ZigBee ID
- Onity locks display as lock's respective serial number. Press **SETTINGS** to select and display -cFg_[lockid]_255



- Press **DOWN** one time to display the **1tag** screen. Then press **SETTINGS** to display **t---**



Custom Energy Savings Settings

- Use **UP | DOWN** buttons to select a tag number (typically 001) and then press **SETTINGS** to set and display **cfg_[lockid]_[tag]**



- Press **DOWN** button 2 times to display **Acc** and then press **SETTINGS** to accept and re-display **Found** screen



- Press **ON | OFF** button to exit the menu system.

Custom Energy Savings Settings

Demand Response

Demand Response (DR) is a resource for balancing power supply and demand by allowing consumers options to reduce or shift their energy consumption away from peak periods.

How it works

- Enroll: Tenant or Property owner opt in to receive DR events
- Integration with Aggregators: DR aggregators linked to the property's utility company integrate with APIs allowing automatic transmission of DR events to thermostats
- Active DR Event Indicator: Thermostats display a distinctive icon alerting tenants and guests a DR event has been sent
- Opt-Out Option: Tenants and Guests may opt out of DR events by adjusting the setpoint

NOTE: DR requires firmware 1130 or later

Custom Energy Savings Settings

Lighting Integration

The thermostat uses built-in infrared motion sensors in conjunction with a wired occupancy sensor to scan a room for occupancy. An auxiliary output provides a binary signal according to real-time occupancy status in the room.

The auxiliary output is wired to a 24VAC relay installed on the lighting circuit; closing the circuit when the room is occupied, and automatically shutting off power to the circuit after occupancy is no longer detected.

A RIB2401B relay is recommended.

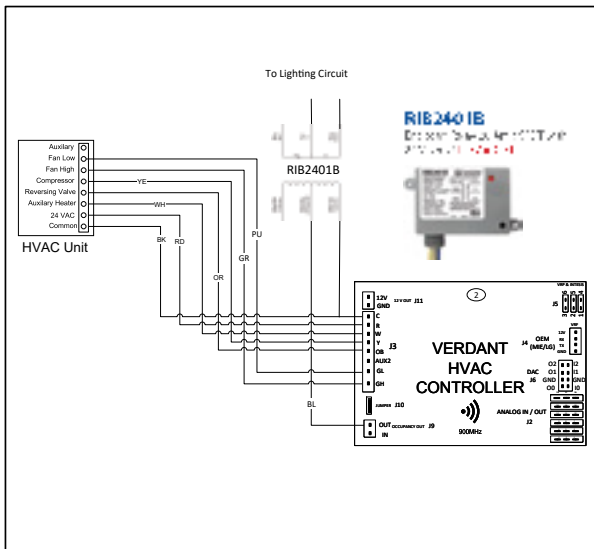

Custom Energy Savings Settings

Setting Index	Max	Min
E1	0	1
E2	70	02
E3	70	05
E4	70	02
E5	20	00
E6	60	00
E7	60	00
E8	23	00
E9	23	00
10	60	00
11	82	62
12	120	00
13	72	52
14	92	72
15	82	62
16	90	60
17	90	60
18	01	00
19	05	00
20	01	00
21	01	00
22	NA	NA

Custom Energy Savings Settings

Setting Index	Max	Min
23	20	04
24	01	00
25	30	05
26	01	00
27	70	55
28	75	65
29	NA	NA
30	01	00
31	60	01
32	08	02
33	10	02
34	50	-50
35	02	00
36	01	00
37	02	00

Custom Energy Savings Settings

01 - FAN CONTROL MODE



<p>Default value: 00 Range: 00-01</p>	<p>00: AUTOMATIC - fan runs only when there is a demand for heating or air conditioning</p> <p>01: CONTINUOUS - fan runs continuously when thermostat is on</p>
---	---

Custom Energy Savings Settings

02 - 1ST STAGE DIFFERENTIAL - HEAT



Default value: 0.5F
Range: 0.2F - 3.0F

Select number of degrees thermostat has to sense between automatic changeover temperature for heat and room temperature before a call for 1st stage heating is initiated.

Custom Energy Savings Settings

03 - 2ND STAGE DIFFERENTIAL - HEAT



Default value: 2.0F
Range: 1.0F - 2.0F

Select difference between 1st stage heating and 2nd stage heating initiation.

This also applies as the 3rd and 4th stage differential on top of the 2nd when there are more than 2 stages.

Custom Energy Savings Settings

04 - 1ST STAGE DIFFERENTIAL - COOL



Default value: 0.5F
Range: 0.2F - 3.0F

Select number of degrees thermostat has to sense between automatic changeover temperature for cool and room temperature before a call for 1st stage cooling is initiated.

Custom Energy Savings Settings

05 - INCIDENTAL OCCUPANCY THRESHOLD



<p>Default value: 5 minutes Range: 0 - 60 minutes</p>	<p>Select minimum period of time (in minutes) for which occupancy needs to be detected to enter guest occupancy mode. When occupancy is detected, thermostat will switch to occupied mode for a duration of Incidental Occupancy Threshold selected.</p> <p>If occupancy is detected for a period of time shorter than the Incidental Occupancy Threshold selected, the thermostat will automatically revert to unoccupied mode at the end of the Incidental Occupancy Threshold period and continue to observe energy saving functions that were in effect before the room became occupied. This setting allows ignoring incidental room visits.</p> <p>If occupancy is detected for a period of time longer than the Incidental Occupancy Threshold selected, the thermostat will enter the guest occupancy mode. When the thermostat is in the guest occupancy mode, it will revert to unoccupied mode and initiate the setback temperature only when occupancy is not detected for the duration of the setback delay (Heat or Cool) period.</p>
---	---

Custom Energy Savings Settings

06 - NIGHT OCCUPANCY THRESHOLD



Default value: 1 minute
Range: 0 - 60 minutes

Select minimum period of time (in minutes) for which occupancy needs to be detected to consider the room occupied during the Night Occupancy period. When occupancy is detected during Night Occupancy Period for longer than the Night Occupancy Threshold selected, the thermostat will instantaneously switch to occupied mode.

If occupancy is detected for a period of time shorter than the Night Occupancy Threshold selected, the thermostat will automatically revert to unoccupied mode and continue to observe energy saving functions that were in effect before the room became occupied.

If occupancy is detected for a period of time longer than the Night Occupancy Threshold selected, the thermostat will disable the occupancy sensor and consider the room occupied until the end of the Night Occupancy period.

This feature ensures energy saving functions that may affect guest comfort will not come in effect during the Night Occupancy period.

Custom Energy Savings Settings

07 - FORCED 2ND STAGE HEATING



Default value: 30 minutes
Range: 0 - 60 minutes

Select a number of minutes 1st stage heating will run before 2nd stage heating is automatically initiated if the guest set point is not reached and the 2nd stage heating is not initiated through differential settings.

This feature allows automatically turning on 2nd stage heating to avoid excessive compressor use. Set to 00 to disable the feature.

This also applies as the 3rd and 4th stage differential on top of the 2nd when there are more than 2 stages.

Custom Energy Savings Settings

08 - NIGHT OCCUPANCY START



Default value: 21 hours
Range: 0 - 23 hours

Select the start time (24-hour clock) for Night Occupancy

If occupancy is detected for a period of time longer than the Night Occupancy Threshold during Night Occupancy period, the thermostat will disable the occupancy sensor and consider the room occupied until the end of the Night Occupancy period.

This feature ensures that energy saving functions that may affect guest comfort will not come in effect during the Night Occupancy period if room was occupied for a period of time longer than Night Occupancy Threshold.

Custom Energy Savings Settings

09 - NIGHT OCCUPANCY END



Default value: 9 hours
Range: 0 - 23 hours

Select time (24-hour clock) for Night Occupancy to end.

The time of day the Night Occupancy ends and the thermostat switches back to the room sensing settings chosen in the other occupancy modes.

Custom Energy Savings Settings

10 - TEMPERATURE RECOVERY TIME



Default value: 25 minutes
Range: 0 - 60 minutes

Select the maximum time allowed for a HVAC unit to attain temperature as defined by Heat and Cool Recovery Temperature;

Temperature Recovery Time selected and the actual temperature recovery ability of the HVAC unit are used to calculate setback temperatures. Calculated setback temperatures maximize energy savings and at the same time ensures a comfortable room temperature (defined as Heat and Cool Recovery Temperature) will be restored within the selected Temperature Recovery Time.

Setting the Temperature Recovery Time to 00, disables temperature recovery. When temperature recovery is disabled, thermostat will use the Minimum and Maximum Setback Temperatures as setback set points.

Custom Energy Savings Settings

11 - RECOVERY TEMPERATURE - HEAT



Default value: 67F
Range: 62F - 82F

Select room temperature in °F that a HVAC unit will have to attain within the selected Temperature Recovery Time when there is a need for heating.

If recovery is disabled (Temperature Recovery Time set to 0) or if setback temperatures have not yet been calculated, the Recovery Temperature - Heat value will be used as the setback temperature for heating.

Custom Energy Savings Settings

12 - TEMPERATURE SETBACK DELAY



<p>Default value: 20 minutes Range: 0 - 120 minutes</p>	<p>Select the time delay (in minutes) for which the room that is in the guest occupancy mode needs to be unoccupied before the temperature setback is initiated.</p> <p>This feature prevents initiating temperature setback prematurely while the guest is still in the room but in an area where occupancy cannot be detected by the occupancy sensor.</p> <p>Setting the Temperature Setback Delay - Heat to 00, disables the setback in the heat mode. Set to 00 to disable EMS.</p>
---	--

Custom Energy Savings Settings

13 - MINIMUM SETBACK TEMPERATURE - HEAT



Default value: 64F
Range: 52F - 72F

Select Minimum Setback Temperature in °F.

Setback temperature is calculated by measuring HVAC unit's ability to attain Recovery Temperature - Heat within Temperature Recovery Time.

If recovery is disabled (Temperature Recovery Time is set to 0) or if setback temperatures have not yet been calculated, the Recovery Temperature - Heat value will be used as the setback temperature for heating.

If calculated setback temperature for heating is lower than Minimum Setback Temperature, then the Minimum Setback Temperature will be used as setback temperature for heating.

This feature allows defining the minimum temperature in a room when room is unoccupied and the thermostat is in the setback mode.

Custom Energy Savings Settings

14 - MAXIMUM SETBACK TEMPERATURE



Default value: 78F
Range: 72F - 92F

Select the Maximum Setback Temperature in °F.

Setback temperature is calculated by measuring HVAC unit's ability to attain Recovery Temperature - Cool within Temperature Recovery Time.

If recovery is disabled (Temperature Recovery Time is set to 0) or if setback temperatures have not yet been calculated, the Maximum Setback Temperature value will be used as the setback temperature for cooling.

If calculated setback temperature for air conditioning is higher than Maximum Setback Temperature, then the Maximum Setback Temperature will be used as setback temperature for air conditioning.

This feature allows defining the maximum temperature in a room when room is unoccupied and the thermostat is in the setback mode.

Custom Energy Savings Settings

15 - RECOVERY TEMPERATURE - COOL



Default value: 74F
Range: 62F - 82F

Select the room temperature in °F that a HVAC unit will have to attain within the selected Temperature Recovery Time when there is a need for air conditioning.

Custom Energy Savings Settings

16 - MINIMUM SET POINT



Default value: 66F
Range: 64F - 84F

Select the minimum set point in °F that a guest can select.

Custom Energy Savings Settings

17 - MAXIMUM SET POINT



Default value: 78F
Range: 60F - 82F

Select the maximum set point in °F that a guest can select.

Custom Energy Savings Settings

18 - TEMPERATURE CONTROL MODE



Default value: AUTOMATIC
Range: 00 - 01

Select Temperature Control Mode:

00: MANUAL - Allows users to select HEAT only or COOL only temperature control mode to maintain the room temperature

01: AUTOMATIC - Thermostat automatically turns on heating or air conditioning to maintain the room temperature at the selected temperature set point

Custom Energy Savings Settings

19 - AUTO CHANGEOVER SET POINT OFFSET



Default value: 1F
Range: 1F - 4F

Select the difference between the guest-selected set point and the heat and the cool set point when the thermostat is in the automatic temperature control mode.

This value plus the 1st stage differential defined in steps 2 and 4, defines the temperature at which the thermostat would automatically change heating/cooling modes.

This feature allows adjusting the deadband between the heat and the cool set points in automatic changeover mode in to avoid the system from bouncing back and forth between heating and cooling under normal operating conditions.

Custom Energy Savings Settings

20 - SETBACK SET POINTS



Default value: 01
Range: 00 - 01

00: When room is unoccupied and the thermostat is in the setback mode or turned off, it will NOT maintain the temperature between heat and cool setback set points.

01: When room is unoccupied and the thermostat is in the setback mode or turned off, it will maintain the temperature between heat and cool setback set points.

Custom Energy Savings Settings

21- AUTO-RESTORE



<p>Default value: 01 Range: 00 - 01</p>	<p>00: When guest enters the room, the thermostat will be turned off - it will not automatically restore the most recent guest settings</p> <p>01: When guest enters the room, the thermostat will automatically restore the most recent guest settings</p>
---	---

Custom Energy Savings Settings

22 - PLACEHOLDER SCREEN

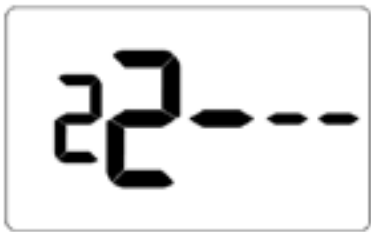

NOTE: for future use.

Custom Energy Savings Settings

23 - SETPOINT OVERTHOOT



Default value: 0.6F
Range: 4F - 20F

Select the °F of overshoot above or below the setpoint on the thermostat before the thermostat stops the call for cooling or heating.

Custom Energy Savings Settings

24 - AUTOMATIC HUMIDITY CONTROL



Default value: 00
Range: 00 - 01

00: Disable automatic humidity control
01: Enable automatic humidity control

When Automatic Humidity Control is enabled, thermostat will turn on air conditioning in an unoccupied room when humidity raises above 60% and room temperature is above 72°F until either room humidity is below 55% or room temperature is below 72°F

This setting is active only on thermostats with enabled humidity features. Changing this setting on a non-humidity thermostat will have no effect on thermostat operation.

Humidity features can be enabled on compatible thermostats via online management.

Custom Energy Savings Settings

25 - 2ND STAGE COOL DIFFERENTIAL



Default value: 2F
Range: 5F - 30F

Select the °F differential required to trigger 2nd stage cooling (if applicable).

This also applies as the 3rd and 4th stage differential on top of the 2nd when there are more than 2 stages.

Custom Energy Savings Settings

26 - SMART SETBACK



Default value: 00
Range: 00 - 01

Smart setback reduces the excessive heating or cooling that may occur when occupants set their thermostats to setpoints outside of the norm. Occupant setpoint that is greater than Cool Setback or less than Heat Setback will be respected during setbacks to save energy.

Custom Energy Savings Settings

27 - HUMIDITY CONTROL THRESHOLD



Default value: 60F
Range: 55F - 70F

Select the relative humidity level that automatic humidity control will attempt to control in conjunction with the humidity cut-off temp.

Custom Energy Savings Settings

28 - HUMIDITY CUTOFF TEMPERATURE



Default value: 72F
Range: 65F - 75F

Select the temperature at which humidity control will shut off.

Custom Energy Savings Settings

29- PLACEHOLDER SCREEN

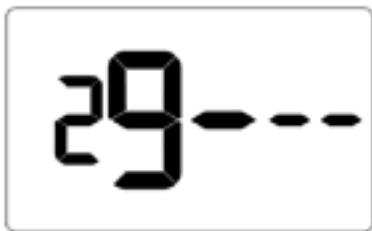

NOTE: for future use

Custom Energy Savings Settings

30- ENERGY MANAGEMENT ON/OFF



Default value: 01 Range: 00 - 01	00: Energy management disabled 01: Energy management enabled
-------------------------------------	---

Custom Energy Savings Settings

31- DOOR/WINDOW SHUT OFF DELAY



Default value: 2
Range: 1 - 60

Select the time delay (in minutes) before the thermostat disables air conditioning when a door or window sensor has been installed.

Custom Energy Savings Settings

32- AUTO FAN SPEED 1ST STAGE DIFFERENTIAL



Default value: 2F
Range: 1F - 8F

Select the °F differential between Low Fan and 2nd stage fan (Medium or High) when Auto-Fan Speed is selected.

Custom Energy Savings Settings

33- AUTO FAN SPEED 2ND STAGE DIFFERENTIAL



Default value: 4F
Range: 2F - 10F

Select the °F differential between Medium and High Fan when Auto-Fan Speed is selected (only active if 3 fan speeds are available).

Custom Energy Savings Settings

34 - TEMPERATURE CALIBRATION



Default value: 0F
Range: -5F - 5F

Calibrate the temperature display

Custom Energy Savings Settings

35 - AUTOMODE TYPE



Default value: 01
Range: 01 - 02

01: Standard Auto Mode - The thermostat will apply the deadband on the guest setpoint and control temperature with the guest setpoint as the median

02: Changeover Auto Mode - The thermostat will apply the deadband as a changeover limit where the deadband is crossed triggering a change in heating or cooling mode

Custom Energy Savings Settings

36 - HUMIDITY CONTROL OCCUPIED ROOM



Default value: 00
Range: 00 - 01

00: Humidity control OFF - The thermostat will disable humidity control when the room is occupied

01: Humidity control ON - The thermostat will enable humidity control even when the room is occupied

Custom Energy Savings Settings

37 - HEAT EQUIPMENT LOCKOUT



<p>Default value: 00 Range: 00 - 02</p>	<p>00: Compressor lockout - If set to 1, the thermostat will only allow electric heat</p> <p>01: Electric heat lockout - If set to 2, the thermostat will only allow compressor heat.</p> <p>02: Equipment lockout is disabled - The thermostat will enable both compressor and electric heat</p>
---	---

Troubleshooting

Restoring Factory Settings

For reported errors or configuration issues, restore settings to thermostat default parameters and re-pair with HVAC Controller.

1. Press and hold the fan and power buttons together for 3 seconds
2. Press and hold **CONFIG** button to move to MESH ID screen
3. Press **F I C** to reach thermostat equipment type configuration screen
4. Press and hold **CONFIG** button until thermostat displays **RST**, then press the **F I C** button
5. Verify thermostat displays **SETUP** after three (3) seconds and reconfigure thermostat

Contact Verdant technical support if the issues are not resolved.

APPENDIX 1 - Energy Saving Presets

Bolded values below indicate the factory default profile*

	Level 0*	Level 1	Level 2	Level 3	Level 4	Level 5
Fan Control Mode	AUTO	AUTO	AUTO	AUTO	AUTO	AUTO
1st Stage Differential Heat	0.5	0.5	0.5	0.5	0.5	0.5
2nd Stage Differential Heat	1.0	1.0	1.0	2.0	2.0	2.0
1st Stage Differential Cool	0.5	0.5	0.5	0.5	0.5	0.5
Guest Occupancy Threshold	0	5	5	5	5	5
Night Occupancy Threshold	1	1	1	1	1	1
Force 2nd Stage Heating After	30	30	30	30	30	30
Night Occupancy Start	18	19	20	21	22	23
Night Occupancy End	12	11	10	9	8	7
Temperature Recovery Time	0	15	20	25	30	0
Recovery Temperature Heat	70	69	68	67	66	65
Temperature Setback Delay	0	30	25	20	15	10
Minimum Setback Temperature	67	66	65	64	63	62
Maximum Setback Temperature	72	74	76	78	80	82
Recovery Temperature Cool	71	72	73	74	75	76
Minimum Set point	64	64	65	66	67	68
Maximum Set point	82	82	80	78	76	74
Temperature Control Mode	AUTO	AUTO	AUTO	AUTO	AUTO	AUTO
Auto Changeover Set Point Offset (Dead Band)	1	1	1	1	1	1

APPENDIX 1 - Energy Saving Presets

	Level 0	Level 1	Level 2	Level 3	Level 4	Level 5
Setback Set Points	OFF	ON	ON	ON	ON	ON
Auto Restore	OFF	ON	ON	ON	ON	ON
N/A						
Setpoint Overshoot	0.6	0.6	0.6	0.6	0.6	0.6
Automatic Humidity Control	OFF	OFF	OFF	OFF	OFF	OFF
2nd Stage Cool Differential	1.0	1.0	1.0	2.0	2.0	2.0
Smart Setback	OFF	OFF	OFF	OFF	OFF	OFF
Humidity Control Threshold	60	60	60	60	60	60
Humidity Cutoff Temperature	72	72	72	72	72	72
N/A						
Energy Management On/Off	OFF	ON	ON	ON	ON	ON
Door/Window Shutoff Delay	2	2	2	2	2	2
Auto Fan Speed 1st Stage Differential	2	2	2	2	2	2
Auto Fan Speed 2nd Stage Differential	4	4	4	4	4	4
Temperature Calibration	0.0	0.0	0.0	0.0	0.0	0.0
Automode Type	STD	STD	STD	STD	STD	STD

APPENDIX 2 - Equipment Codes

	Outputs						
EQPT Code	J3 port						J9 port
Color	White	Yellow	Orange	Purple	Green	Brown	Blue
0101	W1	X	X	X	GH	X	OCC
0102	W1	X	X	GL	GH	X	OCC
0103	W1	X	GM	GL	GH	X	OCC
0302	GH	WCW	WCCW	GL	X	X	OCC
0303	GH	WCW	WCCW	GL	GM	X	OCC
1001	X	Y1	O	X	GH	X	OCC
1002	X	Y1	O	GL	GH	X	OCC
1011	X	Y1	B	X	GH	X	OCC
1012	X	Y1	B	GL	GH	X	OCC
1101	W1	Y1	O	X	GH	X	OCC
1102	W1	Y1	O	GL	GH	X	OCC
1111	W1	Y1	B	X	GH	X	OCC
1112	W1	Y1	B	GL	GH	X	OCC
1201	WAUX	Y1	O	X	GH	X	OCC
1202	WAUX	Y1	O	GL	GH	X	OCC
1211	WAUX	Y1	B	X	GH	X	OCC
1212	WAUX	Y1	B	GL	GH	X	OCC
2001	X	Y1	X	X	GH	X	OCC
2002	X	Y1	X	GL	GH	X	OCC
2003	X	Y1	GM	GL	GH	X	OCC
2100	W1	Y1	X	X	X	X	OCC
2101	W1	Y1	X	X	GH	X	OCC

APPENDIX 2 - Equipment Codes

	Outputs							
EQPT Code	J3 port							J9 port
Color	White	Yellow	Orange	Purple	Green	Brown	Blue	
2102	W1	Y1	X	GL	GH	X	OCC	
2103	W1	Y1	GM	GL	GH	X	OCC	
2106	W1	Y1	X	X	X	X	OCC	
2502	Y1	W1	W2	GL	GH	X	OCC	
5501	Y1	Y2	W1	W2	GH	X	X	
5502	Y1	Y2	W1	W2	GH	X	GL	

	Outputs								Analog output Connections (J6 Port)			
EQPT Code	J3 port							J9 port	O0	GND	O1	O2
Color	White	Yellow	Orange	Purple	Green	Brown	Blue	White	Black	Yellow	Green	
4403	X	X	GM	GL	GH	X	OCC	Analog Heat	GND	Analog Cool	X	
4406	X	X	X	X	X	X	OCC	Analog Heat	GND	Analog Cool	Analog Fan	

APPENDIX 3 - Glossary

"Automatic Fan Control Mode" - fan runs only when there is a demand for heating or cooling;

"Manual Fan Control Mode" - guest can select between automatic or continuous fan operation;

"Minimum Set point" - minimum temperature that a guest can request;

"Maximum Set point" - maximum temperature that a guest can request;

"Auto Changeover Set Point Offset" - the difference between the guest-selected set point and the heat and cool changeover temperatures;

"1st Stage Differential - Heat" - the temperature that the thermostat has to sense between the automatic changeover temperature for heat and the room temperature before a call for the 1st stage heating is initiated;

"2nd Stage Differential - Heat" - difference between 1st stage heating temperature and room temperature before the 2nd stage heating is initiated;

"1st Stage Differential - Cool" - the temperature that the thermostat has to sense between the automatic changeover temperature for cool and the room temperature before a call for the 1st stage cooling is initiated;

"Forced 2nd Stage Heating" - number of minutes 1st stage heating will run before 2nd stage heating is automatically initiated if the guest set point is not reached and the 2nd stage heating is not initiated through differential settings

"Temperature Recovery Time" - the maximum period of time allowed for restoring the "Recovery Temperature";

"Recovery Temperature" - the room temperature that needs to be restored within the "Temperature Recovery Time";

"Maximum Setback Temperature" - the highest room temperature allowed when thermostat is in the setback mode;

"Minimum Setback Temperature" - the lowest room temperature allowed when thermostat is in the setback mode;

"Temperature Setback Delay" - the length of time for which the room that is in the guest occupancy mode needs to be unoccupied before the temperature setback is initiated;

Incidental Occupancy Threshold - the minimum period of time (in minutes) for which occupancy needs to be detected in order to enter the "Guest Occupancy" mode;

Night Occupancy Threshold - the minimum period of time during the Night Occupancy period for which occupancy needs to be detected in order to enter the Night Occupancy mode;

Night Occupancy Period - The period of time during the day during which the Night Occupancy mode can be activated if occupancy longer than the Night Occupancy Threshold is detected;

"Auto Restore On" - thermostat will restore the most recent guest settings when new occupancy is detected;

"Auto Restore Off" - thermostat will NOT restore the most recent guest and will remain turned off settings when new occupancy is detected;

"Setback Set points On" - thermostat will maintain setback temperatures when room is unoccupied;

"Setback Set points Off" - thermostat will NOT maintain setback temperatures when room is unoccupied;

"Incidental Occupancy" - occupancy shorter than the Incidental Occupancy Threshold;

"Guest Occupancy" - occupancy longer than the Incidental Occupancy Threshold;

"Temperature Setback" - thermostat maintains setback temperatures and not the guest set point temperature in order to save energy;

"Night Occupancy Mode" - thermostat status during which setback mode is disabled if occupancy longer than Night Occupancy Threshold is detected within the "Night Occupancy" period;

"Automatic Temperature Changeover" - thermostat automatically activates heating or cooling to maintain the desired room temperature;

"External Thermostat" (Class 2) mode - HVAC unit setting allowing it to be controlled by a remote thermostat;

Warranty Information

Refer to www.verdant.co/verdant-warranty information.

Technical Specifications

Product Type

Thermostat

SKU(s)	Standalone Thermostats VX4-TR-B VX4-TW-B VX4-HW-B VX4-TW-B-GEA VX4-TVF-B VX4-RSR-B VX4-TW-B-CV12 VX4-TW-B-MIE VX4-TW-B-LG VX4-TW-B-TCAB VX4-TVF-B-CV12 VX4-TVF-B-MIE VX4-TVF-B-LG VX4-TVF-B-TCAB VX4-NTR-B VX4-NTW-B VX4-NHW-B VX4-NRSR-B VX4-NTW-B-GEA VX4-NTVF-B VX4-NTW-B-CV12 VX4-NTVF-B-CV12 VX4-NTW-B-MIE VX4-NTVF-B-MIE VX4-NTW-B-LG VX4-NTVF-B-LG VX4-NTW-B-TCAB VX4-NTVF-B-TCAB	EU Thermostats VX4-TR-868-B VX4-TR-868-W VX4-WU-868-B VX4-WU-868-W VX4-TVF-868-B VX4-TVF-868-W VX4-RSR-868-B VX4-RSR-868-W	Networked Thermostats VX4-TR-B-XMF VX4-TW-B-XMF VX4-HW-B-XMF VX4-TW-B-GEA-XMF VX4-TVF-B-XMF VX4-TW-B-CV12-XMF VX4-TW-B-MIE-XMF VX4-TW-B-LG-XMF VX4-TW-B-TCAB-XMF VX4-TVF-B-CV12-XMF VX4-TVF-B-MIE-XMF VX4-TVF-B-LG-XMF VX4-TVF-B-TCAB-XMF VX4-RSR-B-XMF VX4-NTW-B-XMF VX4-NHW-B-XMF VX4-NTW-B-GEA-XMF VX4-NTR-B-XMF VX4-NRSR-B-XMF VX4-NTW-B-CV12-XMF VX4-NTVF-B-CV12-XMF VX4-NTW-B-TCAB-XMF VX4-NTW-B-MIE-XMF VX4-NTVF-B-MIE-XMF VX4-NTW-B-LG-XMF VX4-NTVF-B-LG-XMF VX4-NTVF-B-TCAB-XMF
Wireless Frequency	902-928MHz (NA)		863-870MHz (EU)
Case Dimensions	5.60 x 3.46" x 0.91" (142.3mm x 88mm x 23mm)		
Screen Dimensions	2.60" x 1.65" (66mm x 42mm)		
Operating Voltage	2 x 1.5VDC AA Alkaline Non-rechargeable Batteries - Not Supplied 24VAC or 12VDC		

Technical Specifications

Technical Specifications for Thermostats (cont'd)

Product Type

Thermostat

Control Outputs (24VAC) (1.5A maximum per terminal, 2.5A maximum all terminals combined)	N/A
Power Supply Outlet	N/A
Occupancy Sensor Beam Width	±47° (94°)
Temperature Accuracy	±1°F
Enclosure Material	ABS (AF312C(LG CHEM))
Ambient Operating Temp	32°F -105°F 0 - 41°C
Internet Connectivity	N/A
FCC ID	XEYWX-DB
IC	8410A-WXDB

Product Type

HVAC Controller

Gateway

SKU(s)	ZX-LV-868	ZX-LV	ZX-OL-U-868	ZX-OL-U
Wireless Frequency	863-870MHz (EU)	902-928MHz (NA)	N/A	
Case Dimensions	4.08" x 2.76" x 1.02" 104mm x 70mm x 26mm		4.72" x 3.15" x 1.18" 120mm x 80mm x 30mm	
Operating Voltage	24VAC (20-30VAC) 12VDC (9-15VDC)		12VDC 1.5A	

Technical Specifications

Technical Specifications for HVAC Controller (cont'd)

Product Type	HVAC Controller	Gateway	
Control Outputs (24VAC) (1.5A maximum per terminal, 2.5A maximum all terminals combined)	Fan High (GH)	N/A	
	Fan Low (GL)		
	Compressor (Y)		
	Heat Pump (OB)		
	Electric Heat (W2)		
	Occupancy Out (AUX1)		
	(AUX2)		
Power Supply Outlet	12VDC @ 0.05A (Max)	N/A	N/A
Occupancy Sensor Beam Width	N/A	N/A	N/A
Temperature Accuracy	±1°F	N/A	N/A
Enclosure Material	ABS+PC (TAIRILOY® AC3100 (Formosa Chemicals & Fibre Corporation))	Extruded Aluminum	
Ambient Operating Temp	32°F -105°F 0 - 41°C	32°F -105°F 0 - 41°C	
Internet Connectivity	N/A	100M/1000M Base-T Ethernet	
FCC ID	XEY-ZX-LV		
IC	8410A-ZX-LV		

Technical Specifications

Product Type	Root Node		Sensors	
SKU(s)	ZX-RN-868	ZX-RN	ZX-AOS-868 ZX-DWS-868 ZX-TSW-868	ZX-AOS ZX-DWS ZX-TSW
Wireless Frequency	863-870MHz (EU)	902-928MHz (NA)	863-870MHz (EU)	902-928MHz (NA)
Case Dimensions	2.4" x 1.54" x 0.78" 46mm x 61mm x 19mm		1.82" x 2.4" x 0.74" 46mm x 61mm x 19mm	
Operating Voltage	+5VDC (nom.)		2 1.5VDC AAA Alkaline Non-rechargeable Batteries - Not Supplied	
Control Outputs (24VAC) (1.5A maximum per terminal, 2.5A maximum all terminals combined)	N/A		N/A	
Power Supply Outlet	N/A		N/A	
Occupancy Sensor Beam Width	N/A		±47° (94°)	
Temperature Accuracy	±1°F		±1°F	
Enclosure Material	ABS (AF312C(LG CHEM))		ABS+PC (TAIRILOY® AC3100 (Formosa Chemicals & Fibre Corporation))	
Ambient Operating Temp	32°F -105°F 0 - 41°C		32°F -105°F 0 - 41°C	
Internet Connectivity	N/A			
FCC ID	XEY-ZX-RN		XEYZ9RF	
IC	8410A-ZXRN		8410A-Z9RF	



THIS DEVICE COMPLIES WITH PART 15 OF THE FCC RULES. OPERATION IS SUBJECT TO THE FOLLOWING TWO CONDITIONS: (1) THIS DEVICE MAY NOT CAUSE HARMFUL INTERFERENCE, AND (2) THIS DEVICE MUST ACCEPT ANY INTERFERENCE RECEIVED, INCLUDING INTERFERENCE THAT MAY CAUSE UNDESIRE OPERATION.

THE MANUFACTURER IS NOT RESPONSIBLE FOR ANY RADIO OR TV INTERFERENCE CAUSED BY UNAUTHORIZED MODIFICATIONS TO THIS EQUIPMENT. SUCH MODIFICATIONS COULD VOID THE USER'S AUTHORITY TO OPERATE THE EQUIPMENT

This device complies with Industry Canada license-exempt RSS standard(s). Operation is subject to the following two conditions: (1) this device may not cause interference, and (2) this device must accept any interference, including interference that may cause undesired operation of the device.

Le présent appareil est conforme aux CNR d'Industrie Canada applicables aux appareils radio exempts de licence. L'exploitation est autorisée aux deux conditions suivantes : (1) l'appareil ne doit pas produire de brouillage, et (2) l'utilisateur de l'appareil doit accepter tout brouillage radio électrique subi, même si le brouillage est susceptible d'en compromettre le fonctionnement.

Under Industry Canada regulations, this radio transmitter may only operate using an antenna of a type and maximum (or lesser) gain approved for the transmitter by Industry Canada. To reduce potential radio interference to other users, the antenna type and its gain should be so chosen that the equivalent isotropically radiated power (e.i.r.p.) is not more than that necessary for successful communication.

Conformément à la réglementation d'Industrie Canada, le présent émetteur radio peut fonctionner avec une antenne d'un type et d'un gain maximal (ou inférieur) approuvé pour l'émetteur par Industrie Canada. Dans le but de réduire les risques de brouillage radioélectrique à l'intention des autres utilisateurs, il faut choisir le type d'antenne et son gain de sorte que la puissance isotroperayonnée équivalente (p.i.r.e.) ne dépasse pas l'intensité nécessaire à l'établissement d'une communication satisfaisante.

COVERED BY ONE OR MORE OF THE FOLLOWING PATENTS. US PATENTS: 8,369,994; 8,141,791; 7,918,406; 7,232,075; 7,185,825; 7,156,318; 7,152,806; 7,145,110; 7,050,026; 7,028,912; 6,902,117; 6,789,739; 6,786,421; 6,619,555; 6,581,846; 6,578,770; 7,838,803; 7,841,542; D556,061; D518,744; RE40,437; CANADIAN PATENTS: 2,633,113; 2,633,200; OTHER PATENTS PENDING.

Verdant Environmental Technologies, Inc. reserves the right to make changes, without notice, in design or components. Product appearance may vary. © Verdant Environmental Technologies, Inc. 2021.
Printed in Canada. **V.1** JANUARY 2022 (REFVX3220112)

TECHNICAL SUPPORT: verdant.support@emerson.com 1-877-318-1823